

Show all holes on the drawing unless otherwise specified.  
 The cutting process is the property of SCHNEIDKOPF.

100 mm  
 90  
 80  
 70  
 60  
 40  
 30  
 20  
 10  
 0

MICROFILMED

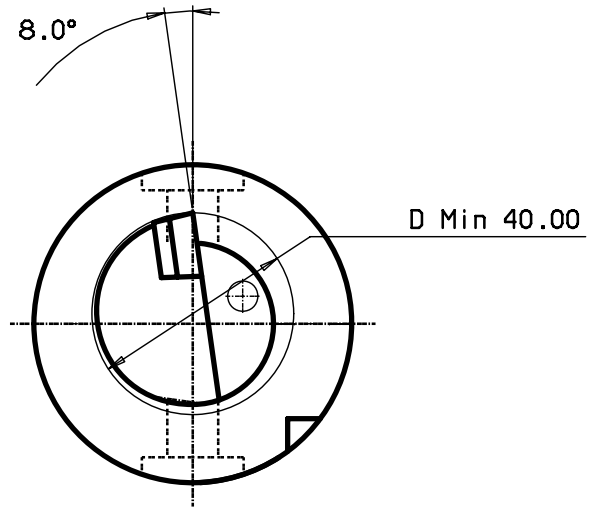
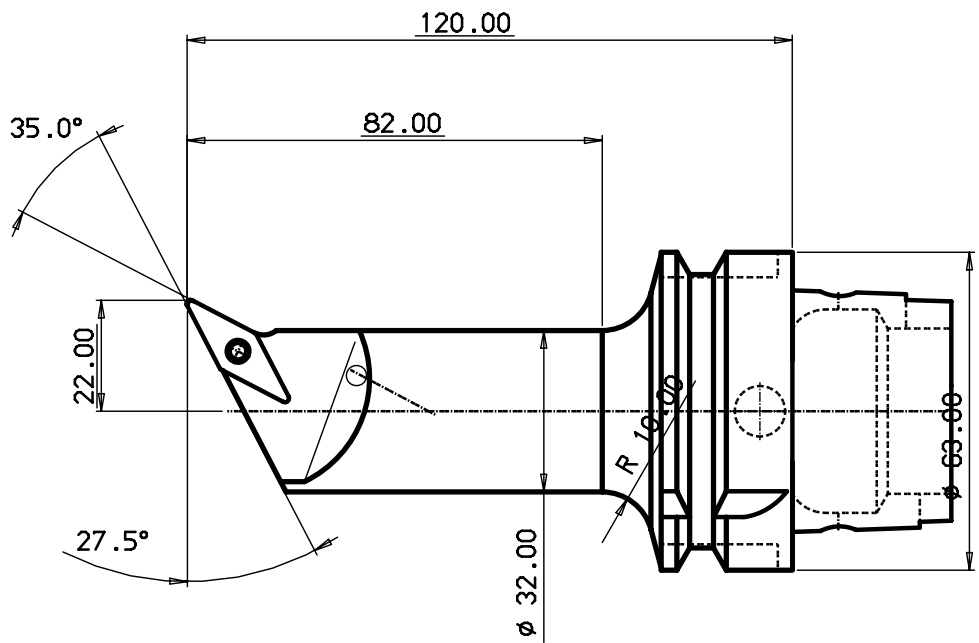

HM-Platte VBMT 160404

ITEM	QNTY	DESCRIPTION	MATERIAL AND REMARKS	RELATED DRAWING	UNIT	SIZE
4	1	Schraube f. Zw				5512 090-01
3	1	Zwischenlage				5322 270-01
2	1	Schraube f. Platte				5513 020-01
1						

CATEGORY	DESIGNED	DRAWN	CHECKED	DATE	SCALE	SUPERSEDES

TITLE

**Schneidkopf  
Cutting-Unit**

REFERENCE

MODIFICATION

A	B	C	D	E	F	G	H	I	J	K	L	M	N	P	R	S	T	U	V	X	Y	Z
---	---	---	---	---	---	---	---	---	---	---	---	---	---	---	---	---	---	---	---	---	---	---

DESIGN OFFICE | DRAWING NUMBER

**HSK63A-SVQBL-2232120-16**

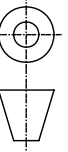

340-0700-2

MOD.	LOCATION	CHANGE REFERENCE	DATE	SIGN

Tolerance systems acc to ISO

Surface roughness Ra um

Where tolerance not stated:  
For threads SS-iso 965/3  
For dimensions SS 715 Medium

Dimension	Tol	Angle (Shortest adjacent side in mm)	Tol
(6) - 30	±0.10	10	± 1'
(30) - 120	±0.20	10	± 30'
(120) - 315	±0.30	(10) - 50	± 20'
(315) - 1000	±0.50	(50) - 120	± 10'
		(120) -	