

When a part is not dimensioned, it is not to be made to the same standard as the part it is being replaced by. The drawing shows the proper way to dimension a part.

DESIGN OFFICE | DRAWING NUMBER

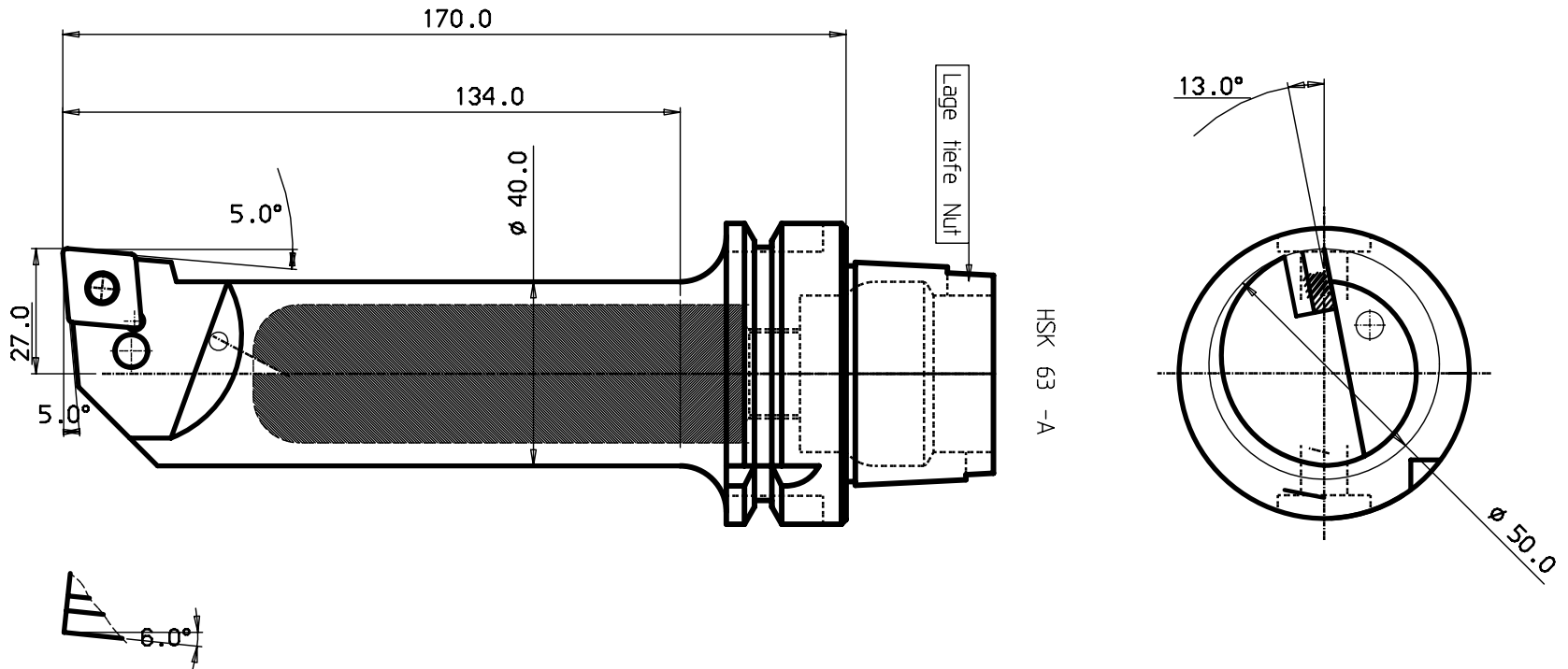

HSK 63 - A

HM-Platte CN..160608

5	1	Schraube	438.3-831
4	1	Rohrstift	174.3-864
3	1	Unterlage	
2	1	Kniehebel	438.3-840
1			

ITEM	QNTY	DESCRIPTION	MATERIAL AND REMARKS	RELATED DRAWING	LIBR	ISSR
CATEGORY	DESIGNED	DRAWN	CHECKED	DATE	SCALE	SUPERSEDES

TITLE: **Schneidkopf**

REFERENCE: _____

MODIFICATION: _____

DESIGN OFFICE: _____

DRAWING NUMBER: **HSK63A-PCLNL-2740170-16**

Tolerance systems acc to ISO
 Surface roughness Ra um

Where tolerance not stated:
 For threads SS-iso 965/3
 For dimensions SS 715 Medium

Dimension	Tol	Angle (Shortest adjacent side in mm)	Tol
(6) - 30	+0,10	10	± 1'
(30) - 120	+0,30	10	± 30'
(120) - 315	+0,50	150 - 120	± 20'
(315) - 1000	+0,80	120	± 30'

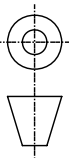

340-07000-2

100 mm
 90
 80
 70
 60
 50
 40
 30
 20
 10
 0

MICROFILMED

MOD | LOCATION | CHANGE | REFERENCE | DATE | SIGN