

When a hole is used to create a thread, the hole is not a hole and the thread is not a thread. The drawing must be prepared in accordance with the drawing.

MICROFILMED

100 mm
 90
80
70
60
40
30
20
10
0



340-07000-2

DESIGN OFFICE | DRAWING NUMBER

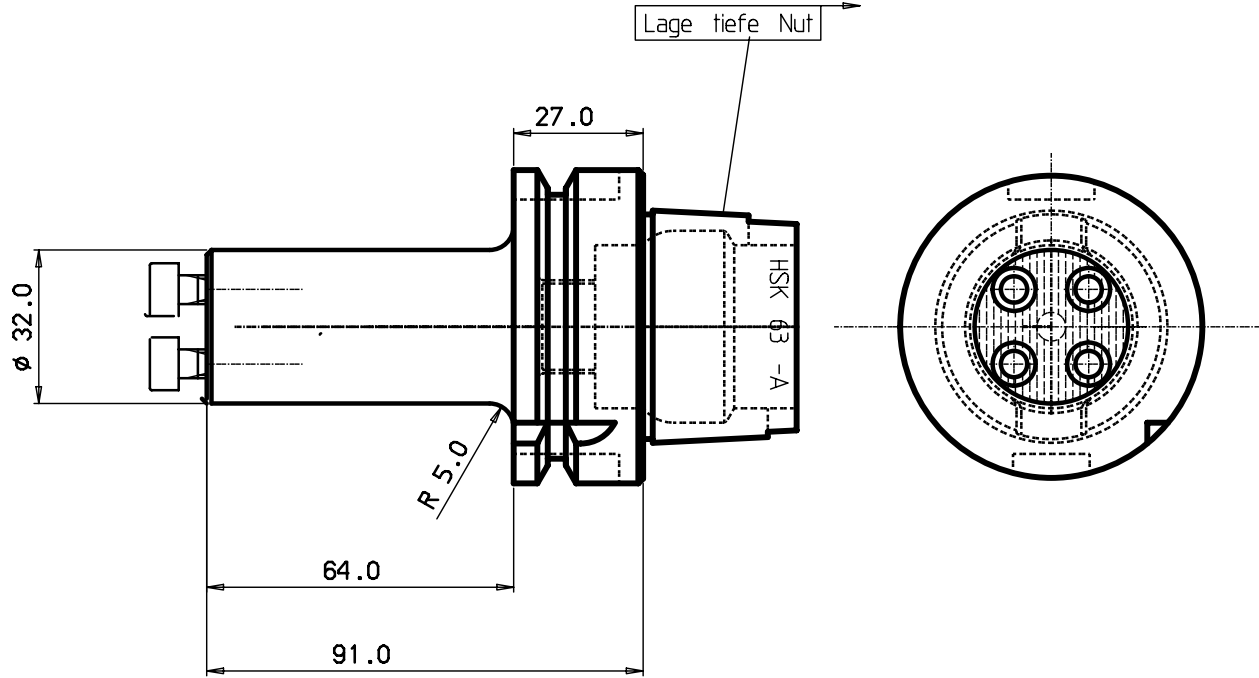

MOD.	LOCATION	CHANGE REFERENCE	DATE	SIGN

Tolerance systems acc to ISO
 Surface roughness Ra μm

Where tolerance not stated:
 For threads SS-iso 965/3
 For dimensions SS 715 Medium

Dimension	Tol	Angle (Shortest adjacent side in mm)	Tol
-6	±0.10		
60 - 90	±0.20		
90 - 120	±0.30	10	± 1'
120 - 315	±0.50	15	± 30'
315 - 1000	±0.80	20 - 120	± 20'
		120 -	± 30'

ITEM	QNTY	DESCRIPTION	MATERIAL AND REMARKS	RELATED DRAWING	DATE	SCALE	SUPERSEDES	ITEM	DATE
CATEGORY	DESIGNED	DRAWN	CHECKED	DATE	SCALE	SUPERSEDES			
TITLE		<i>Adapter</i>							
REFERENCE		MODIFICATION		ABCDEFGHIJKLMNPQRSTUWXYZ					
		DESIGN OFFICE DRAWING NUMBER		HSK63A-570-2C-32091					

