

Show a detail over the complete line of a part only
 and do not be used when an assembly is shown
 this drawing means the priority of the drawing

100 mm
 90
 80
 70
 60
 40
 30
 20
 10
 0

MICROFILMED

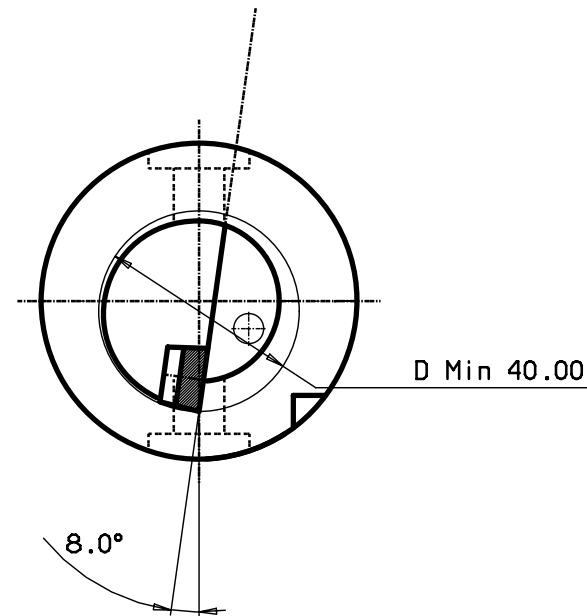
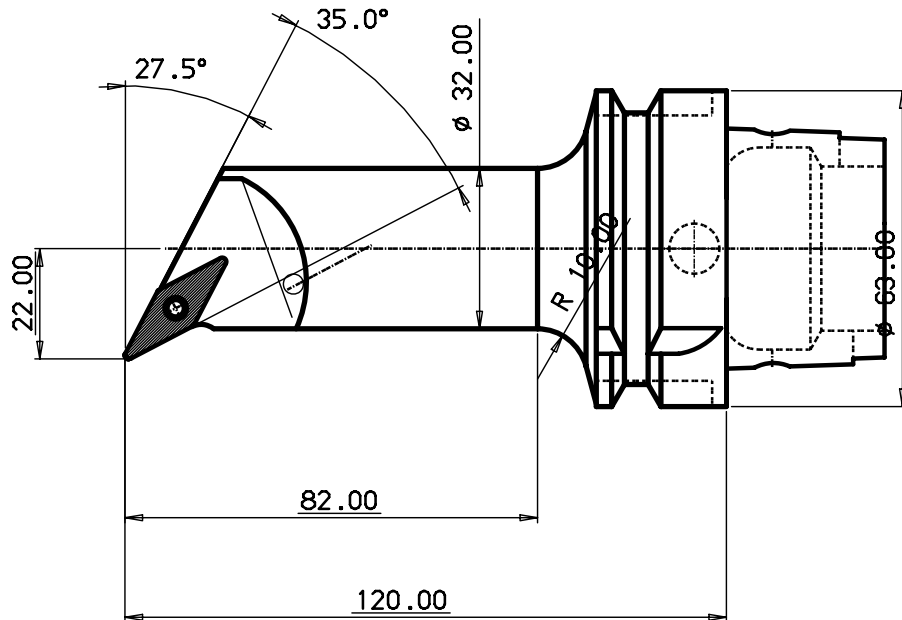

HM-Platte VBMT 160404

ITEM	QNTY	DESCRIPTION	MATERIAL AND REMARKS	RELATED DRAWING	REP.	SIZE
4	1	Schraube f. Zw		5512 090-01		
3	1	Zwischenlage		5322 270-01		
2	1	Schraube f. Platte		5513 020-01		
1						

Tolerance systems acc to ISO
 Surface roughness Ra um

Where tolerance not stated:
 For threads SS-ISO 965/3
 For dimensions SS 715 Medium

Dimension	Tol	Angle (Shortest adjacent side in mm)	Tol
-6	±0.10	10	± 1'
(6) - 30	±0.20	10	± 30'
(30) - 120	±0.30	(10) - 50	± 20'
(120) - 315	±0.50	(50) - 120	± 10'
(315) - 1000	±0.80	(120) -	

**Schneidkopf
 Cutting-Unit**



ITEM	QNTY	DESCRIPTION	MATERIAL AND REMARKS	RELATED DRAWING	REP.	SIZE
4	1	Schraube f. Zw		5512 090-01		
3	1	Zwischenlage		5322 270-01		
2	1	Schraube f. Platte		5513 020-01		
1						

CATEGORY	DESIGNED	DRAWN	CHECKED	DATE	SCALE	SUPERSEDES

TITLE: **Schneidkopf Cutting-Unit**

REFERENCE: _____

MODIFICATION: _____

DESIGN OFFICE: _____

DRAWING NUMBER: **HSK63A-SVQBR-2232120-16**

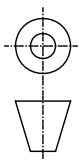

340-07010-2

MOD.	LOCATION	CHANGE	REFERENCE	DATE	SIGN