

MOD	LOCATION	CHANGE REFERENCE	DATE	SGN	1	2	3	4	5	6	7	8
					1	2	V 3	4	5	6	7	8
					2	2	3	4	5	6	7	8

DESIGN OFFICE | DRAWING NUMBER

Show a detail view to complete this drawing and add a note to the detail view of HSK63A-PCLNR-22085-12. This drawing is the property of HAVRANEK COMPANY.

100 mm  
 90  
 80  
 70  
 60  
 40  
 30  
 20  
 10  
 0

MICROFILMED

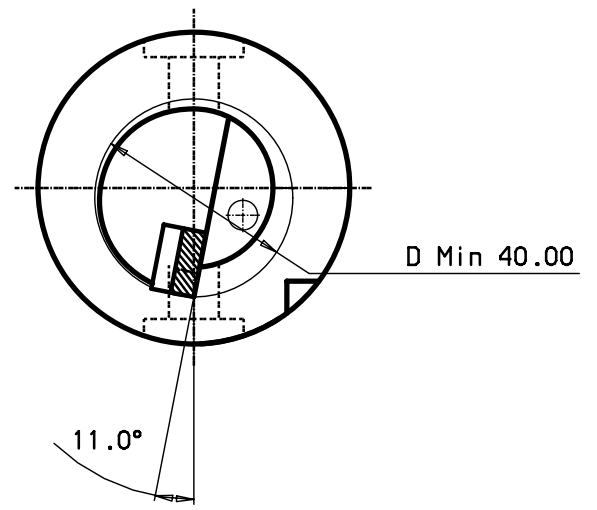
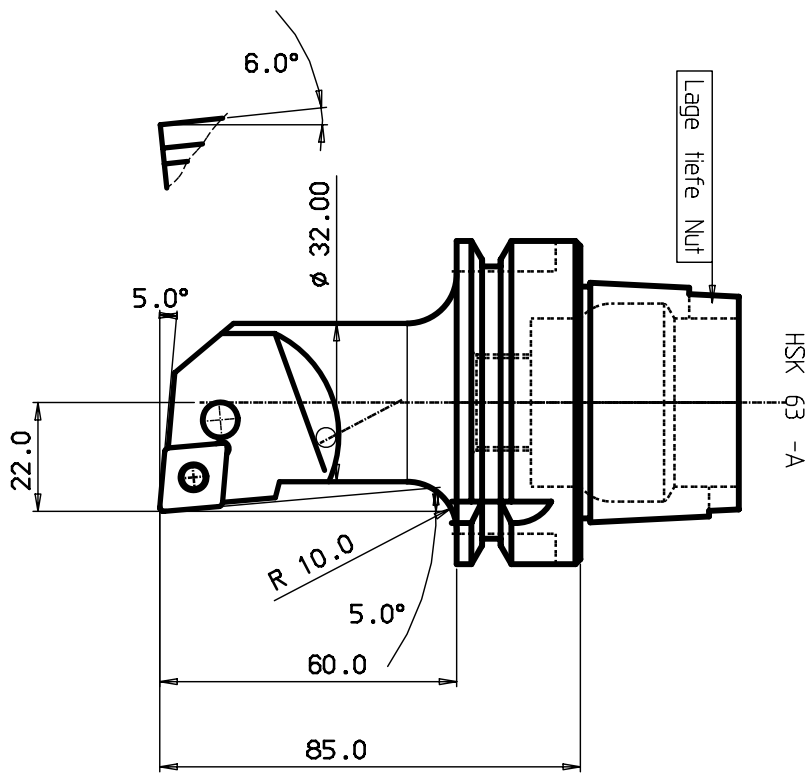

HM-Platte CN.. 120408

5	Schraube	174.3-821
4	Rohrstift	174.3-861
3	Unterlage	171.31-850M
2	Kniehebel	174.3-841M
1	Schaft	

ITEM	QNTY	DESCRIPTION	MATERIAL	AND REMARKS	RELATED DRAWING	UTM	1:50
CATEGORY	DESIGNED	DRAWN	CHECKED	DATE	SCALE	SUPERSEDES	

Tolerance systems acc to ISO  
Surface roughness Ra um

Where tolerance not stated:  
For threads SS-iso 965/3  
For dimensions SS 715 Medium

Dimension	Tol	Angle (Shortest adjacent side in mm)	Tol
60 - 30	+0.10	10	± 1'
90 - 120	+0.20	10	± 30'
120 - 315	+0.30	10	± 30'
315 - 1000	+0.50	10	± 30'
	+0.80	10	± 30'

REFERENCE: ABCDEFGHIJKLMNOPQRSTUVWXYZ

MODIFICATION: ABCDEFGHIJKLMNOPQRSTUVWXYZ

DESIGN OFFICE | DRAWING NUMBER

**HSK63A-PCLNR-22085-12**

MOD	LOCATION	CHANGE REFERENCE	DATE	SGN	1	2	3	4	5	6	7	8
					1	2	V 3	4	5	6	7	8

